



Chapter 34 – Flexitanks

A flexitank is a bladder designed to fit inside a 20 ft general freight container, thereby converting the freight container into a non-hazardous bulk liquid transportation unit. As defined by the IMO/ILO/UNECE *Code of Practice for Packing of Cargo Transport Units (CTU Code)* (Reference 57), a flexitank is a '*bladder used for the transport and/or storage of a non-regulated liquid inside a CTU*'. Flexitanks are not an approved form of packaging for the carriage by sea of dangerous goods classified under the *International Maritime Dangerous Goods Code (IMDG Code)* (Reference 19).

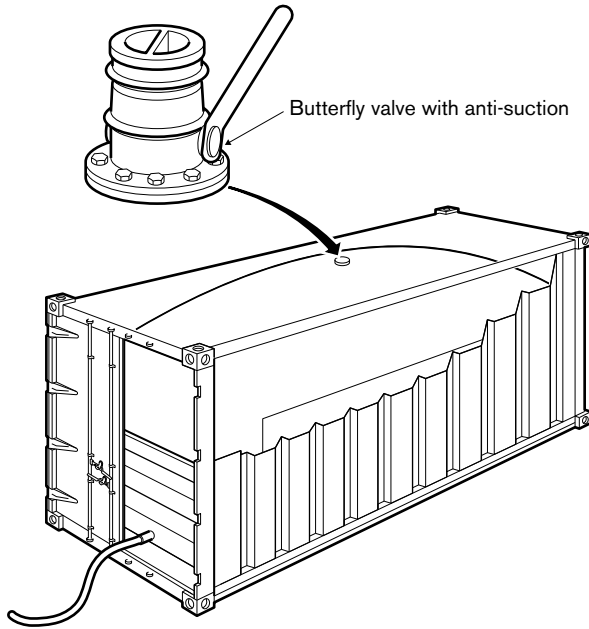

Figure 34.1: Flexitank in a container.

A large number of claims have arisen relating to containers carrying flexitanks, where the pressure placed on the sidewall panels inside the containers has resulted in them bulging beyond accepted ISO external dimensions and tolerances, leading to permanent deformation. The International Organization for Standardization (ISO)/Institute of International Container Lessors (IICL) deformation limit for sidewall panels is a maximum of 10 mm beyond the plane of the side surfaces of the corner casting fittings. This limit has been exceeded in many incidents, so some operators have imposed limits on the quantity of liquid that may be carried in a flexitank.



Figure 34.2: Bulging flexitanks.

34.1 COA Code of Practice for Flexitanks

In 2011, the Container Owners Association (COA), Flexitank Division, published a Code of Practice to improve the quality and safety of flexitank operations. Compliance with this Code is not mandatory (Reference 58). The current version of the COA *Code of Practice for Flexitanks* was published in 2019 and contains the guidance provided in the IMO/ILO/UNECE *Code of Practice for Packing of Cargo Transport Units* (CTU Code) published on 16th December 2014 (Reference 57).

Under the *Code of Practice*, the COA provides a mechanism for each COA flexitank manufacturer to obtain a COA Compliance Certificate showing their compliance with the Code subsequent to audits for their quality management system, installation and training, material test and rail impact test. The certificate confirms that the manufacturer endorses the COA declaration and has undergone audit in all four areas. The COA also maintains a FQML (Flexitank Quality Management List) on this website to record the manufacturers who have received COA certification.

Alongside the Code of Practice, the British Standards Institution (BSI) has developed specification BSI PAS 1008 *Specification for the performance and testing of a single-use flexitank* (Reference 59). PAS 1008 is sponsored by COA and provides detailed specifications for testing materials, performance and labelling of all components in the flexitank system.

34.2 Perceived Advantages/Disadvantages

In the non-hazardous markets, single-use flexitanks are considered by some to be effective substitutes for ISO tank containers and drums. Some of the reasons for this include:

- Flexitanks are product dedicated and so there is no risk of cross contamination
- relatively low positioning costs (in some areas, 100 empty flexitanks can be positioned for the same cost as one tank container)
- positioning a flexitank with a capacity of up to 24,000 litres inside a 20 ft general freight container enables shippers to dispatch about 40% more cargo per container than a drummed consignment, about 50% more than a bottled consignment and about 15% additional payload when compared to a container filled with intermediate bulk containers (IBCs). No return loads are required
- loading rates are higher compared to drums and IBCs
- flexitank manufacturers obtain approvals from authorities such as the USA's FDA (Food and Drug Administration), the EU-approved Food Safety System Certification (FSSC) 22000 and the UK's HACCP (Hazard Analysis and Critical Control Point) to ensure compliance with food products.

The disadvantages of flexitanks include:

- Products classified as dangerous goods under the IMDG Code (Reference 19) are not permitted to be carried in flexitanks
- pumps are required for unloading older flexitanks, although newer tanks are fitted with loading/unloading valves

- greater preparation is required for flexitanks than for ISO tank containers, although ISO tanks require substantial cleaning, particularly in food applications
- environmental issues arise in connection with the disposal of used single-trip flexitanks
- the risk of leakage of the full contents
- the potential for high costs to clean up spillages
- spillage resulting in the contamination of other cargo, depending upon stowage on board.



Figure 34.3: Flexitanks damage.

34.3 Types of Flexitanks

A range of products are carried in flexitanks, including wine, fruit concentrate, animal fat, fish oil, base oil, detergents, non-hazardous chemicals, drilling mud additives, paint, lubricants, printing ink, latex and potable water. The choice of flexitank is based on the cargo carried and factors such as the duration of the voyage and the temperature difference between load and discharge port.

Flexitanks can be either single layer or multilayer. Single layer flexitanks (SLFs) are generally manufactured from a single thick layer of polyethylene of 40 mm thickness. Multilayer flexitanks (MLFs) can consist of several layers (two, three or more), depending on the type of cargo being carried and the shipper's requirements. Generally, the value of the cargo will determine the protection required in the carriage and, therefore, the number of layers required for the MLF being used. For example, cargoes that require a barrier against taint contamination will use four layers. Each layer of an MLF may be about 125 microns thick. The outer layer of an MLF is normally of a woven type plastic material. A problem with MLFs is that the different layers may, during loading, get caught up and trapped, resulting in a layer tearing.

The first flexitanks were designed on the basis that they would be for multi-trip use, which meant that cleaning and repositioning costs were incurred. However, these costs have been eliminated with the single trip/use flexitank, which is the type now most commonly in use, accounting for more than 95% of the global market.

Flexitanks are required to be marked with the performance test standard, manufacturer's name and logo, unique serial number and capacity at the time of manufacture. These markings must be located on the flexitank in such a way that they are visible when the right-hand door of the container is opened.

34.4 Free Surface Effect

A free surface effect can occur in liquids, or in masses of small solids, if they move about during transport in partly filled tanks, including ballast and fuel tanks. It also occurs in containers that are only partially full and when this happens it can alter the centre of gravity of the ship so that, instead of righting itself as it rolls on passage, the ship leans further over to one side and may capsize.

In October 2002, the container ship ‘*Westwood Rainier*’ began to list while in port in Seattle. The upper port ballast tank was seen to be pumping out water immediately prior to the 35 to 40° list developing. While a problem with the ballast water system seems to have been the cause of the list, it may have been exacerbated by a free surface effect in the tanks.

If a flexitank is not filled to near its nominal capacity, a marked free surface effect and hydraulic surging of the liquid may occur, often resulting in damage to the container. A flow meter should be used to ensure that a flexitank has been filled to its correct capacity (± 500 litres of its nominal capacity) because a visual inspection alone is unlikely to be sufficient.

A large number of partially filled flexitanks can have a significant adverse impact on ship’s stability. Masters must, therefore, be supplied with relevant information so that they can incorporate any loss of stability due to partially filled flexitanks into their stability calculations.

The typical capacity of a flexitank is in the range of 10,000 to 24,000 litres and the weight carried will depend on the density of the commodity. The permitted gross weight of a container should never be exceeded. Current practice is not to load more than 24,000 kg of liquid in a 20 ft freight container, although even this is considered too high by some container operators.

34.5 Flexitank Container Characteristics

The 20 ft containers for carriage of flexitanks should be rated to a minimum 30,480 kg, irrespective of the size of the flexitank. The actual sidewall strength is a function of a container’s permitted payload, ie $0.6 \times \text{payload}$ (ISO 1496-1 *Series 1 freight containers – specification and testing* (Reference 60)). Therefore, the sidewall panels of a 30 T container will have been tested to a greater load bearing capability than, say, a 24 T container.

The sidewall test requires a general freight container to be subjected to an internal loading uniformly distributed and arranged to allow free deflection of the sidewall and its longitudinal members. This test proves the ability of a container to withstand all forces that can result from the movement of a ship at sea. The ISO Standard requires that, upon completion of the test, the container exhibits neither permanent deformation that will render it unsuitable for use, nor any abnormality that will render it unsuitable for use, and that the dimensional requirements governing handling, securing and interchange are satisfied. Therefore, for a 30 T container, the test load will be of the order of 16.8 T. However, a flexitank does not place a uniform loading over the full area of a sidewall and a gross liquid cargo weight of 24,000 kg is the recommended

maximum by some flexitank operators, while some container operators consider that there should be a lower limit. Any general purpose container may be used as currently there is no specific classification of containers for the carriage of flexitanks.

To minimise the stress upon the sidewalls of a freight container, it is recommended that the height of the side of the flexitank in contact with the sidewall panel should be kept to a minimum. An optimum height of 1.3 m has been suggested.

It is also recommended by flexitank operators that the sidewall panels are fully corrugated from end to end and that a container with sidewall decal panels and flat logo panels is not acceptable.

Containers used for flexitanks are required to display a CSC plate and must be part of a valid PES (periodic examination scheme) or ACEP (approved continual examination programme). When used, the containers must be in a good state of repair in compliance with shipping line criteria such as UCIRC (Unified Container Inspection and Repair Criteria).

The container should be fitted with:

- Functioning dual locking bars for each door panel
- left-hand door handles that have a hole to accept a safety bolt seal
- door recesses for bulkhead fixings.

34.6 Inspection of Freight Container Prior to Use

Regardless of whether a single or multi-trip flexitank is being used, a freight container should be inspected to ensure the following:

- The container is structurally undamaged and free from sharp projections on internal side and end wall panels and floor
- the container is in a clean condition and free from the residue of all previous cargoes
- any joints in the welds are smooth, ie no rough edges or cracks in the welding or otherwise in the structure of the container
- there are no floor imperfections:
 - floorboards and their retaining bolts are flush
 - there are no nails in the floor (nails/screws/fastenings should not be hammered into the floor)
 - the underside of the container floor should also be inspected to ensure that no nails are protruding and that all cross members are in place and firmly affixed to the floor and the side rails and do not show signs of excessive deformation and/or cracking
 - internal weld joints are smooth; rough weld joints can result in a flexitank being abraded (placing tape over the weld joints can provide extra protection)

- cams on both doors are positioned and lock correctly when the doors are closed
- handles are positioned and lock fully in their hatches
- door recesses for bulkhead fixings are in good condition (note: containers are being built without door recess channels which makes them unable to accommodate bulkhead fittings)
- lashing fittings at bottom rails and corner posts should be undamaged to reduce the risk of punctures
- bolts affixing labels etc to the doors are not protruding through to the inside of panels. If they are, they must be covered with foam or cardboard
- any traces of oil found on the container walls or floor must be cleaned. If it cannot be cleaned, such as oil soaked into a timber floor, it must be reported to avoid subsequent claims on an incorrect party.

Some flexitank operators provide a standard practice checklist for container selection. If the container does not meet the criteria laid down, the flexitank operator's technical department should be notified.

To protect the flexitank from abrasion against bare metal, the normal practice is to line the inside of the container. Materials often used include corrugated cardboard, Styrofoam sheets and kraft paper.



Figure 34.4: Use of kraft paper.

To prevent a loaded flexitank bulging outwards when the right-hand door is open, a false bulkhead of plastic panels held in place with horizontal steel bars that fit into the vertical corrugation in the door pillars is placed in the doorway.

To ensure that a flexitank does not bulge through the gaps in a steel framework bulkhead, a sufficiently rigid sheet should be placed on the inside of the bulkhead. This prevents the flexitank chafing against the steelwork. Figure 34.5 shows horizontal steel bars used with cardboard sheeting placed between the flexitank and the steel bars.



Figure 34.5: Use of protective cardboard sheets.

34.7 Stowage of Flexitanks

The stowage of flexitanks on board a vessel needs to be considered in the context of two factors, which may be conflicting, ie the forces acting on the container and the nature of the goods.

To reduce forces acting upon the container and the flexitank, stowage low down in the hold and near to the ship's centreline is preferable. Such forces can be particularly high when the ship is partly loaded and/or has a large metacentric height (GM), resulting in a short rolling period. However, if the nature of the goods is such that they could solidify in the event of a leak (eg latex) and could result in the ship's hold bilge lines becoming blocked, then on-deck stowage is preferable.

Ship operators may also wish to consider whether, due to the nature of the goods, a leak could result in tainting of the hold space and/or other container loads stowed in the same hold.

The information supplied by the shipper should include full details of the nature of the product and whether it could solidify, taint or damage the container in the event of a leak. On balance, the optimum stowage for flexitanks is probably the first tier, on deck.

Even though the cargo carried in flexitanks is considered to be non-dangerous and, therefore, does not necessarily require Safety Data Sheets (SDS), in order for the carrier to be aware of the risks associated with the cargo, the shipper must provide an SDS so that appropriate action can be taken in the event of spillage of cargo on the ship.

34.8 Labelling of Containers

It is normal practice to place a warning label on the left-hand door panel of the freight container to highlight the risk that the container is fitted with a flexitank. The label must be in English and at least one other language of the shipper or the consignee. This label should be printed on a placard of at least A4 size (210 × 297 mm) that is capable of withstanding the harshness of the sea for at least 90 days. It should advise:

- Caution bulk liquid
- flexitank container
- keep left-hand door shut, ie do not open the left-hand door until discharge is complete
- do not loose shunt
- no forklift truck
- emergency contact information.

The *Code of Practice for Flexitanks* recommends only one label, but this presupposes that this single label will be seen by the person handling the container. This may not be the case for the operator of the crane loading or discharging the vessel or the driver of the vehicle moving the container to/from the quayside to its storage location on the terminal (Reference 58). It also presupposes that the label is in a language understood by the person handling the container at any particular time in the transport chain.

Any markings on the container indicating carriage of a flexitank must be removed as soon as the flexitank is discharged.

34.9 Flexitank Safety

For ease of discharge, bottom fittings adjacent to the doorway are generally preferred. However, this can result in a static head of pressure between the flexible body of the tank and the valve construction. Leaks can occur due to the detachment of the double patch around the valve opening of either the top or bottom fittings.



Figure 34.6: Flexitank valve.

A damaged container does not automatically mean that a flexitank will leak. However, if a flexitank does leak and its full load is spilt, then, depending on the commodity being carried, the clean-up costs may be considerable. Additionally, daily demurrage costs on quarantined leaking flexitanks may be charged by shipping lines if the shipper/consignee is unable to provide the emergency assistance required.

A flexitank can sustain severe trauma without leaking. Figure 34.7 shows a flexitank full of synthetic latex stowed at the bottom of a flooded hold. There was no leakage and the product was later sampled, approved and discharged for its intended use.



Figure 34.7: Flood-damaged flexitanks containing undamaged latex.

However, problems do arise, such as with wine which expands excessively if it ferments in a flexitank, see Figure 34.8.



Figure 34.8: Damage caused by fermentation of wine.

In this case, while the sidewall and roof panels of the container were damaged, there was no leakage of the wine. This is one reason why relief valves are not used on some designs. While relief valves are suitable for the rigid design of tanktainers, there are complex problems in designing one suitable for a flexitank. The fitting of relief valves in the early flexitanks led to criticism of the containers, as there was frequently leakage of the contents during shipment.

However, to put the problem into perspective, the number of incidents involving wine, similar to that shown in Figure 34.8, was three or four out of a total of 28,000 carried for one flexitank operator.

As the technology continues to develop, flexitank manufacturers are starting to use 40 ft containers to transport liquid cargoes. It is estimated that these containers will be capable of carrying some 27,000 litres of liquid in one container. These flexitanks will also utilise heating pad systems to heat prior to discharging.

A number of underwriters have refused to insure flexitank shipments due to the risk of leakage, particularly where there is the potential for damage to the environment. It is therefore recommended that the following precautions are taken for all shipments involving flexitanks:

1. The shipper is to provide the carrier with:
 - a) details of the product being shipped
 - b) details of the manufacturer of the flexitanks to check whether they are on the COA approved list
 - c) the serial number of the flexitank, added to the bill of lading (B/L).
2. If the flexitank manufacturer is not on the COA approved list, the carrier may still accept the shipment provided the shipper is able to provide the required information, such as for the criteria specified in the COA *Code of Practice*, and is certified by an independent auditing authority.
3. In all cases, the shipper must provide 24-hour emergency contact details.
4. The personnel operating the flexitank, ie installing it in the container, and loading or unloading cargo, must be trained as required by the COA.
5. Depending on the nature of the cargo being carried, the flexitanks must be filled to their capacity, leaving only 5% space unfilled to allow for expansion. Shippers should establish additional requirements based on the temperature difference between load/discharge ports and transit areas and their impact on cargo expansion etc. If the flexitank is not full to capacity, the Master of the ship must be informed to allow for free surface effect calculations to take place.
6. Carriers must record the condition of the container loaded with a flexitank upon receipt on board, notifying any anomalies to the shipper immediately. The Master must exercise their right to refuse any cargo where a doubt exists as to the integrity of the container or its contents.

34.10 Charterparty Contracts

In charterparty contracts, owners and charterers should identify who will be responsible for costs and damages in the event of leakage from flexitanks while on board. In addition, when B/Ls are issued, they should be claused to identify the party responsible for positioning and loading the flexitank in the container.



Price: £95

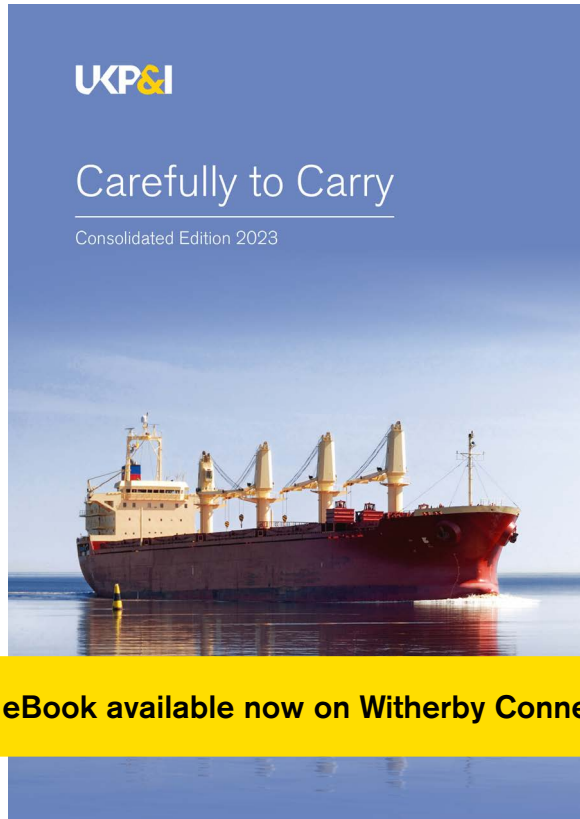

This comprehensive publication, compiled by the UK P&I Club, details best practice for the carriage, loading and storage requirements of a wide range of cargoes. It also contains essential information on draught surveys and preparing cargo plans.

Outlining and expanding on all major international cargo regulations and guidelines, it also includes detailed checklists, information on draught surveys and guides to preparing cargo plans. Cargoes covered include timber, gas, grain, steel and other metals, bulk goods and refrigerated goods.